

9 January 1997

AN ELECTROSTATIC SOLUTION FOR THE GRAVITY FORCE AND THE VALUE OF G

By Morton F. Spears

<https://www2.econ.iastate.edu/tesfatsi/MFSpears/index.htm>

Abstract: Gravity is electrostatic. This paper substantiates this claim by deriving, through basic electrostatic relationships, a simple equation for gravity forces that includes an expression for the gravity constant G in terms of electrostatic parameters. Applied to interaction between two separated sub-atomic particles in open space, the derivation of G results in a value that falls within the range of the currently best known and accepted empirical measurements. The general electrostatic gravity equation next derived is applicable for all physical entities however small or large, thus presenting a comprehensive new way of perceiving and understanding gravity forces. A variety of other important conclusions also follow. For example, the electrostatic approach helps to explain why experimenters who use different physical layouts may continue to find different empirical values for G regardless of the precision of their measurements.

1. Introduction

This paper begins with the introduction of electrostatic equations for finding a capacitance force between two electrons. The equations are derived from the model in Figure 1 which depicts two electrons positioned in separate hydrogen atoms one meter apart. The hydrogen atoms are assumed to have no relative motion and are situated in ϵ_0 permittivity open-space. The parameters Q , V , r^* , r , K and P for the equations below pertain to electrostatic values derived from the model. The expanded force equation shown contains all the parameters required to effect the force solution, and the standard values for the parameters (in the MKS system of units) are presented either directly below or in Table 1. By equating the resultant electrostatic force F_{ge} to Newton's empirical gravity force $F_{gN} = G M_e M_e / r^2$ between two electrons at the same separation, a new value of G (signified by G_e in MKS electrostatic units) is defined. The resultant force F_{ge} and term G_e are calculated as follows:

$$F_{ge} = (1/2)QV / r^* = (1/2)KQV / r.$$

After substituting derived expressions for K , Q and V respectively,

$$F_{ge} = (1/2)[4\pi\epsilon_0 R_e^2 \text{ farad} - \text{meters} / 1 \text{ farad} - \text{meter}][Q_e][Q_p / (P+1)4\pi\epsilon_0 r] / r.$$

Then substituting known values from Table 1, finally

$$F_{ge} = -5.54779 \times 10^{-71} \text{ coulomb-volts/meter, or } -5.54779 \times 10^{-71} \text{ newtons.}$$

Using Newton's expression for the gravity force, let $F_{ge} = G_e M_e^2 / r^2$ so that G_e may be defined as

$$G_e = F_{ge} r^2 / M_e^2 . \text{ Then, after substituting known values,}$$

$$G_e = -6.68541 \times 10^{-11} \text{ (coulomb-volt-meters)/(kilograms)}^2 .$$

The minus sign determines that the force obtained is attractive, which occurs in Coulomb expressions and in the electrostatic expanded equation above, since the product of $Q_e \times Q_p$ is a negative quantity. This convention of negative attractive forces is used throughout this paper.

Taken from Reference [4], the widely accepted value of G in terms of mass-times-acceleration forces in MKS units (and with the minus sign convention) is:

$$G = -6.67259(85) \times 10^{-11} \text{ (meters)}^3 / \text{(kilogram)(seconds)}^2 .$$

Note that the two numerical magnitudes for G and G_e agree within 0.2%. Because of this close agreement, F_{ge} is, with almost certain probability, the actual gravity force between the two electrons.

To convert the expression for the special-case F_{ge} gravity force between two electrons to a general-case expression for the F_g gravity force between any two bodies, a multiplier term A is provided. A is the ratio of the capacitance between bodies 1 and 2 to the capacitance between two electrons, with the same spacing r and same permittivity ϵ_{12} between the pairs. Then

$$\begin{aligned} A &= (4\pi\epsilon_{12}R_1R_2 / r) / (4\pi\epsilon_{12}R_e^2 / r) \\ &= R_1R_2 / R_e^2 . \end{aligned}$$

Thus, $F_g = F_{ge}A = [(1/2)KQV / r][R_1R_2 / R_e^2]$, where the R_1 and R_2 terms represent the *effective* radii of bodies 1 and 2, and R_e is the *effective* radius of the electron.

In this electrostatic approach to gravity, explained later herein and in Reference [1], with a very detailed mathematical analysis shown on pages 38-40 of Reference [2]:

$$R_1 / R_e = C_1 / C_e = M_1 / M_e ;$$

$$R_2 / R_e = C_2 / C_e = M_2 / M_e .$$

Thus, $A = M_1 M_2 / M_e^2$.

Since $F_g = (1/2)KQVA / r$, substituting derived values for K, Q, V and A results in

$$F_g = (1/2)[8.83538 \times 10^{-40}][Q_e][Q_p / (P+1)4\pi\epsilon_0 r][M_1 M_2 / M_e^2] / r ,$$

and, by filling in the known values for the parameters used,

$$F_g = -6.68541 \times 10^{-11} M_1 M_2 / r^2 \text{ coulomb-volts/meter, or newtons.}$$

The three progressive expressions just shown for F_g are derived from a force between two electrons and show clearly, without any reference to Newton's gravity force expression, that

$$G = G_e = -6.68541 \times 10^{-11} \text{ (coulomb-volt-meters)/(kilograms)}^2 .$$

Next, the values of G from empirical measurements presented in Reference [4], and from the electrostatic calculations in this paper, are shown in ascending order of magnitude without the minus sign convention:

Determinations of the Gravitational Constant, G

Fitzgerald <i>et al.</i>	$6.6656(6) \times 10^{-11}$	$m^3 / kg \ s^2$
Meyer <i>et al.</i>	6.6685×10^{-11}	$m^3 / kg \ s^2$
Currently accepted value	$6.67259(85) \times 10^{-11}$	$m^3 / kg \ s^2$
Spears (electrostatic units)	6.68541×10^{-11}	$C \ V \ m / kg^2$
Michaelis <i>et al.</i>	6.71540×10^{-11}	$m^3 / kg \ s^2$

XX

NOTE BY LEIGH TEFATSION (June 2, 2010; Revised May 31, 2024) :

In the above listing of determinations for the gravitational constant G , the electrostatic unit CVm/kg^2 for G as derived by M. F. Spears is equivalent to the standard unit m^3/kgs^2 for G as usually derived. To see this, consider the following sequence of definitions and identities expressed in Standard International (SI) units as presented in the official SI brochure:

<https://www.nist.gov/publications/international-system-units-si-2019-edition>

derivation for an attractive force F_{ge} generated between the two poles of a capacitor in free space follows.

Consider the physical system consisting of a capacitor, C , that has a pole-to-pole length $r(C)$ measured in meters, with a pole-to-pole total elastance $S(C)$ measured in darafs and with a pole-to-pole potential difference $V(C)$ measured in volts. Let $D(C)$ denote the total number of meters associated with C , a pure number, so that $r(C) = D(C)$ meters. Let $M(C)$ denote the total number of volts associated with C , a pure number, so that $V(C) = M(C)$ volts. And let $N(C)$ denote the total number of darafs associated with C , a pure number, so that $S(C) = N(C)$ darafs. For ease of notation, the dependence of these quantities on the physical system C will henceforth be suppressed.

Let K denote the pole-to-pole total number of meters associated with C divided by the pole-to-pole total number of darafs associated with C ; that is, let $K = D/N$, so that K is a pure number.

By electrostatic law, $V = Q \times S$, where the Q is measured in volts per daraf. Let v denote the volts associated with one daraf, so that $v = Q \times [1 \text{ daraf}]$, an expression measured in volts that is invariant to the units in which darafs are measured.

Let r^* denote the length in meters of one daraf for the capacitor C , so that r^* is defined by the following relation:

$$r^* \times K = r .$$

Note that from these definitions and relations:

$$\begin{aligned} V/r^* &= VK/r \\ &= [Q \times S]D/Nr \\ &= [Q \times N \text{ darafs}]D/Nr \\ &= [Q \times 1 \text{ daraf}]D/r \\ &= vD/r , \end{aligned}$$

so that V/r^* is measured in volts per meter and is invariant to the units in which darafs are measured.

Consider the usual electrostatic force equation for the physical system C :

$$F = (1/2)QV / r .$$

Converting to r^* , one obtains

$$F = (1/2)QV / r = (1/2)QV / Kr^* .$$

However, one can define another force, F_{ge} , by:

$$F_{ge} = (1/2)QV / r^* = (1/2)KQV / r = KF .$$

The force F_{ge} , which has the magnitude of a gravity force and is therefore assumed to be one, is derived as shown from electrostatic definitions and relationships.

The K term denotes the D/N ratio (number of meters divided by the number of darafs) for the capacitance under consideration. In the Figure 1 physical system, where C_{12} is used in the model to derive the F_{ge} force between two electrons, the number of meters D is $(r \text{ meters}) / (1 \text{ meter})$, a pure number, and the number of darafs N is $(r / 4\pi\epsilon_0 R_e^2 \text{ darafs}) / (1 \text{ daraf})$, a pure number, so that the ratio is:

$$\begin{aligned} K &= [(r \text{ meters}) / (1 \text{ meter})] / [(r / 4\pi\epsilon_0 R_e^2 \text{ darafs}) / (1 \text{ daraf})] \\ &= (4\pi\epsilon_0 R_e^2 \text{ farad-meters}) / (1 \text{ farad-meter}) \\ &= 8.83538 \times 10^{-40} . \end{aligned}$$

One more pure number term A , as shown in the Introduction, is used to expand the special-case expression for the F_{ge} gravity force between two electrons to a general-case expression for the gravity force F_g between any two bodies, so that:

$$F_g = KQVA / 2r , \text{ where}$$

$$A = (4\pi\epsilon_{12} R_1 R_2 / r) / (4\pi\epsilon_{12} R_e^2 / r) = R_1 R_2 / R_e^2 = M_1 M_2 / M_e^2 .$$

K and A are pure numbers that remain invariant to the units applied to the expression for finding the gravity force in a given capacitance C physical system.

To assist in understanding the electrostatic approach used, and the Solution Derivation section which follows this section, a number of definitions and explanations are next provided.

Effective radius: This is the radius assigned to an object as if it were a perfect conducting sphere that permits one to determine precisely the capacitance of that object to another object, or to the background space around it. For example, the capacitance C_{12} between two Objects 1 and 2, spaced at a great distance r_{12} between their centers, is $4\pi\epsilon_{12} R_1 R_2 / r_{12}$, where R_1 and R_2 are the effective radii of Objects 1 and 2, respectively, and ϵ_{12} is the permittivity of the intervening space between the two objects. The capacitance to the

background C_1 for Object 1 is $4\pi\epsilon_1 R_1$, and the capacitance to the background C_2 for Object 2 is $4\pi\epsilon_2 R_2$, where ϵ_1 and ϵ_2 are the permittivities of the medii surrounding Objects 1 and 2, respectively. The separation distance r_{12} must be much greater than the radii R_1 and R_2 for the above expressions to be accurate. Also, for electrostatic gravity, the linking capacitance V/S "field" is so minute that electrons are not moved out of position in objects on which the "field" impinges, which permits the full-strength "field" to react with all of the individual particles in that object. When this happens, even very dense metals or any other materials appear as relatively immense open-spaces with tiny particles distributed throughout the volume.

When an object consists of a cluster of very much smaller particles, and they are far-spaced from each other relative to their individual effective radii, the effective radius of the total conglomerate of particles (effective radius of the object) is the sum of all of the effective radii of the individual particles. However, when the smaller particles are forced closer together, the total effective radius is less than the sum of the individual particles' radii. For example, the total measured capacitance to the background (ground) for two 7.6 centimeter aluminum balls, spaced far away from each other, is simply $2C$, where C is the capacitance $4\pi\epsilon R$ of each ball. When the balls are moved closer together, their total summed capacitance to the background decreases, finally reducing to about $1.4C$, or about seven-tenths of the separated total capacitance, when the balls actually touch. The effective radius for the two touching balls is then $1.4R$, or about 10.6 centimeters.

This effect is exactly what happens with masses: that is, a mass is always equal to, or smaller than, the sum of its individual particle masses. It is smaller than the sum when the individual sub-atomic or atomic particles are packed close together. A mass M , for example, is the total sum mass M_t of the individual particle masses times a mass-ratio M / M_t . For electrostatic linkages between particles derived in this paper, a hydrogen mass-ratio $M / M_t = 1$ is used, and is based upon hydrogen with a mass exactly equal to the sum of the proton and electron masses. There should be negligible error with this approach since the nearest particle in hydrogen to the electron, for example, is at least 18,000 times its effective radius away. The conclusion from the above is that capacitances, effective radii, and masses using very minute V/S "fields" all follow the same principle, so that:

For mass-ratios, $C / C_t = R / R_t = M / M_t$.

For the proton-to-electron ratio, $C_p / C_e = R_p / R_e = M_p / M_e = P = 1836.15$.

For any object-to-electron ratio, $C / C_e = R / R_e = M / M_e$.

The above relations are used in this electrostatic approach to find precise gravity forces and G between particles from the size of electrons up to sizes of galaxies or greater. Chapters 5 and 6 of Reference [2] provides a more detailed discussion of capacitances, effective radii, and masses as used for electrostatic determination of gravity forces.

The most important radius used in this paper as a basis for determining the electrostatic gravity force is the effective radius of the electron. This radius can be found from Einstein's energy-mass relation formula $E = Mc^2$, where c is the velocity of light in ϵ_0 permittivity space. The total energy of an electron is $Q_e^2 / C_e = Q_e^2 / 4\pi\epsilon_0 R_e = M_e c^2$. Thus,

$$R_e = Q_e^2 / 4\pi\epsilon_0 M_e c^2 = 2.81795 \times 10^{-15} \text{ meters.}$$

QV/r Suppression: This is the cancellation plus attenuation of normal V/r fields that ensures sufficient reduction of the Coulomb charge forces to permit unaffected derivation of QV/2S (or QV/2r*) gravity magnitude forces. In Figure 1, the following five attributes of a hydrogen-to-hydrogen interaction are considered.

- 1) The charge magnitudes of the proton and the electron are identical with plus and minus values respectively; that is, $Q_p = -Q_e$.
- 2) In Figure 1, the distance between the individual sub-atomic particles of the reference hydrogen atom to the individual particles in the second hydrogen atom is one meter plus or minus twice the hydrogen atom radius when there is a rotation of the two sub-atomic particles with respect to each other in both atoms. This means that a very minute rotating V/r field vector is present at each atom from the rotating dipole of the other atom. However, these fields impinge on charges of equal plus and minus values resulting in force cancellation; that is, two rotating force vectors of equal magnitude, but 180° out of phase, act upon the proton and electron respectively in each atom.
- 3) The integration over time of any residual rotating force vector not cancelled to zero, if any, produces a zero magnitude continuous force. The moment of inertia of an object on which the field impinges, for example, will filter out any residual rotating V/r force and leave only the continuous force, which is zero.
- 4) Furthermore, in actual situations, there are not just two hydrogen atoms involved at a given separation, but a vast number of dipole atoms, all producing very diminutive rotating force vectors in random phase relationship that, when summed, statistically cancel toward zero.
- 5) The proof that the QV/r effects are sufficiently suppressed in actuality is that no coulomb forces can be measured between bodies composed of equal numbers of plus and minus charges; but note that gravity forces can still be measured.

V/S "field" strength: This is the normal magnitude of a "field" so minute that all objects and materials appear to be open spaces sparsely peppered with tiny particles. The word "field" is in quotes because the V/S voltage gradient, which has the unit of charge, is not usually thought about at all, much less as a field. However, the unit of one daraf for S has a real length for capacitors that consist of two separated particles in space. Because of this, the gradient has the ability to produce a force when impinging on a charged particle. This force is proportional to QV/S. The force is so small that it cannot move electrons, or other charged particles, which are fixed in place within a body by relatively huge Coulomb

forces. Without any charged particles' responsive movements, there is neither electrical conductivity nor polarization to cancel the "field", which then impinges on every particle within a body no matter how deeply imbedded. Actually, the V/S "field" travels with less attenuation through a particle-filled body than through open space. References [1] and [2] both explain this phenomenon by showing that the capacitance of an air-spaced capacitor is increased when fine metallic particles are distributed in the space between the poles. Just as important, there is no Faraday shield possible for the minuscule "fields". Even a sheet of silver, for example, readily allows the "field" to pass through because, without electrical conductivity, it is not possible to short-circuit the "field" by attaching separated particles of the silver to ground.

3. Solution Derivation

Before presenting the model and electrical circuits in space that result in equations for the correct magnitude of gravity forces and G in any systems of units, a preliminary discussion of the technique is in order.

When there is a V/S "field" between entities, the S represents a number of darafs (the inverse units of capacitance) spaced linearly with distance between the entities. For the capacitance between two electrons in free space separated by one meter, for example, there are 1.13181×10^{39} darafs calculated to run in a straight line between electron 1 and electron 2, and there is also one meter of distance running in a straight line between 1 and 2. Each daraf then corresponds to 8.83538×10^{-40} meters in field distance terms. This permits one to convert the volts/daraf "field" to a very small conventional volts/meter field and to obtain forces directly in terms of newtons, rather than in some unit of force which must then be converted to newtons by additional manipulations, as was done in Reference [1]. For small particle entities with more capacitance between them, say an electron and a proton, the number of darafs is less than between two electrons at the same distance. This results in a greater volts/daraf value, a greater volts/meter field and a greater $KQV/2r$ force, all of which should become clear in the approach to follow. A permittivity change in the S path medium between any two entities could also slightly affect the gravity force between them. However, the analysis in this paper uses a fixed $\epsilon = \epsilon_0$ free space as the medium between separated particles for the determination of their gravity forces and G .

In this approach two separated electron entities 1 and 2 are used as a basic reference for gravity with each of the electrons as part of a hydrogen atom. The protons in the hydrogen atoms ensure that all of the normal V/r electric fields between the two hydrogen atoms are cancelled in the path between the atoms, and effectively in the nearly same path between the electrons. The second electron 2 is then considered only for its effective radius, neglecting any effect of its charge which has been cancelled out at position 1. All calculations are performed to find the forces with respect to position 1.

The gravity forces and G_e about to be defined and quantified are derived with the particles motionless with respect to each other, all in one three dimensional spacial reference system. The constants, symbols and units used are all standardized in the MKS system of units, with magnitude values given to six places. Specific electrostatic

expressions and component values are taken from Reference [3], a college-level physics instruction book by Robert Resnick and David Halliday. See Table 1 for a tabulation of the most important parameter values used in this paper.

<u>Parameter Constant</u>	<u>Symbol</u>	<u>Value</u>
Elementary Electron Charge	Q_e	-1.60219×10^{-19} coulombs
Balanced Proton Charge	Q_p	1.60219×10^{-19} coulombs
Mass of Electron	M_e	9.10953×10^{-31} kilograms
Proton/Electron Mass Ratio	P	1836.15
Permittivity of Vacuum Space	ϵ_0	8.85419×10^{-12} farads/meter
Speed of Light in Vacuum Space	c	2.99792×10^8 meters/second
Effective Radius of Electron*	R_e	2.81795×10^{-15} meters

* $R_e = Q_e^2 / 4\pi\epsilon_0 M_e c^2$

Table 1. A Glossary of Constants

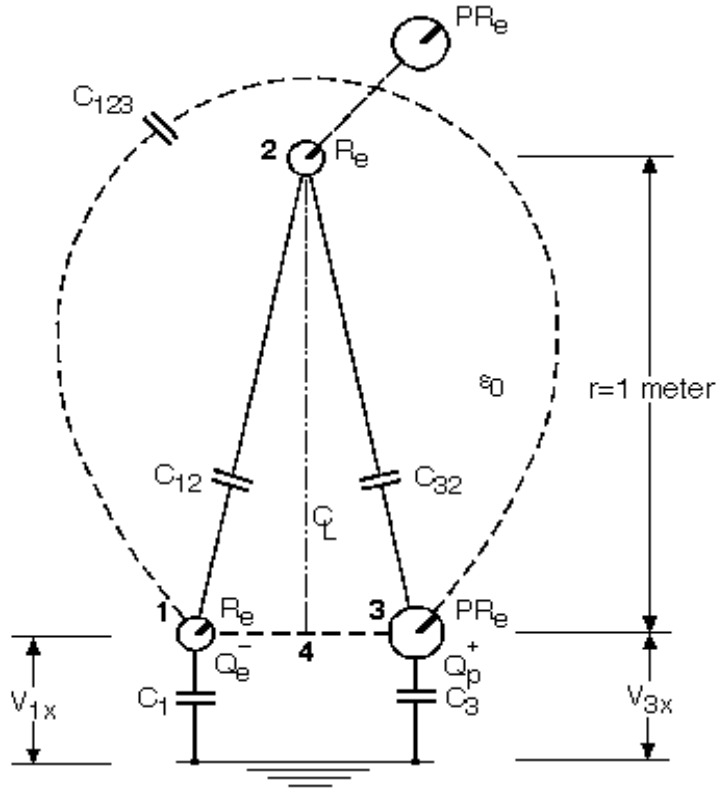

Notes:

C_{123} denotes C_{12} and C_{32} in series

V_{1x} and V_{3x} are induced voltages through C_{123}

Figure 1. Model to Derive Electrostatic Force Between Two Electrons in Separated Hydrogen Atoms

Figure 1 presents the model diagram used as a basis to compute F_{ge} and F_g gravity forces in all electrostatic terms, and from these, the value of G used as the empirical multiplier constant in the Newton mass-driven expression for a gravity force.

Figure 1 depicts a hydrogen atom with an electron at position 1 having a negative charge Q_e^- , an effective radius R_e , and a capacitance C_1 to the background. In the same hydrogen atom, there is a proton at position 3 with a positive charge Q_p^+ , an effective radius of PR_e , and a capacitance C_3 to the background. P is the proton-to-electron radii ratio. The center-line distance from this hydrogen atom to the electron at position 2 in a second hydrogen atom is arbitrarily chosen as 1 meter, with the two atoms situated in permittivity ϵ_0 free space. C_{12} is the capacitance from the electron at position 1 to the electron at position 2. C_{32} is the capacitance from the proton at position 3 to the electron at position 2. C_{123} represents the capacitance from the electron at position 1 to the proton at position 3 via the electron at position 2, and is the capacitance obtained with C_{12} and C_{32} in series. V_{1x} is the induced voltage relative to the background at the electron in position 1, which is initiated by the charge of the proton in position 3, and transferred as a positive voltage to position 1 via C_{123} . V_{3x} is the induced voltage relative to the background at the proton in

position 3, which is initiated by the charge of the electron at position 1, and transferred as a negative voltage to position 3 via C_{123} . The magnitude of V_{1x} is derived using the circuit in Figure 3, and is used in the expression for the force between the electron poles of C_{12} . The magnitude of the voltage relative to the background, V_{3x} , when derived in the same manner as V_{1x} , is equal in magnitude but reversed in polarity; that is, $V_{3x} = -V_{1x}$. V_{3x} could be used in an expression (not shown in this paper) to find the force between the proton and electron poles of C_{32} , but would only be redundant in view of the more general method used here for expanding the electron-to- electron force to forces between other particles or larger bodies.

The expressions for the values of the components in Figure 1 are as follows:

$$R_e = Q_e^2 / 4\pi\epsilon_0 M_e c^2 = 2.81795 \times 10^{-15} \text{ meters};$$

$$P = R_p / R_e = M_p / M_e = 1836.15;$$

$$\epsilon_0 = 8.85419 \times 10^{-12} \text{ farads/meter};$$

$$C_1 = 4\pi\epsilon_0 R_e \text{ farads};$$

$$C_3 = 4\pi\epsilon_0 P R_e \text{ farads};$$

$$C_{12} = 4\pi\epsilon_0 R_e^2 / r \text{ farads};$$

$$C_{32} = 4\pi\epsilon_0 P R_e^2 / r \text{ farads};$$

$$C_{123} = C_{12} C_{32} / (C_{12} + C_{32}) = [P / (P + 1)] 4\pi\epsilon_0 R_e^2 / r \text{ farads};$$

$$Q_p^+ = (-Q_e^-) = 1.60219 \times 10^{-19} \text{ coulombs};$$

$$V_{1x} = (Q_p^+ / C_3) \times (C_{123} / C_1) = Q_p^+ / (P + 1) 4\pi\epsilon_0 r \text{ volts};$$

$$V_{3x} = (Q_e^- / C_1) \times (C_{123} / C_3) = Q_e^- / (P + 1) 4\pi\epsilon_0 r \text{ volts}.$$

For ease of notation, the plus and minus signs shown as exponents for the proton and electron charge polarities will henceforth be deleted.

Since the term S applied to elastance of capacitors in units of darafs is not generally required in electrostatics, the following expressions for the elastance of C_{12} and C_{32} are included below for clarification:

$$S_{12} = r / 4\pi\epsilon_0 R_e^2 = 1.13181 \times 10^{39} \text{ darafs}$$

$$S_{32} = r / 4\pi\epsilon_0 P R_e^2 = 6.16406 \times 10^{35} \text{ darafs}.$$

Figure 2, which represents the Figure 1 model as an equivalent electrical circuit, is next provided to show all the component values, and to show from the vantage point of position 1 or position 3 that a particle at position 2 is always at zero potential relative to the background because of its position in the capacitance divider network. Also, if one travels along the center-line path from the first hydrogen atom (position 4 in Figure 1) to the electron at position 2, there would always be zero potential relative to the background encountered due to equal distances from the positive proton charge at position 3 and from the negative electron charge at position 1. Without a potential, there can be no V/r field along the path. Reversing the situation, the electron at position 2, from the vantage points of 1 or 3, appears as a particle at zero background potential due also to the cancellation of all V/r fields coming from the proton and electron combination in the far-spaced hydrogen atom. Furthermore, even the induced V_{1x} and V_{3x} equal magnitude diminutive voltages shown in Figure 1 produce no V/r fields between positions 1 and 2 since V_{1x} is positive, V_{3x} is negative, and their V/r sum is zero.

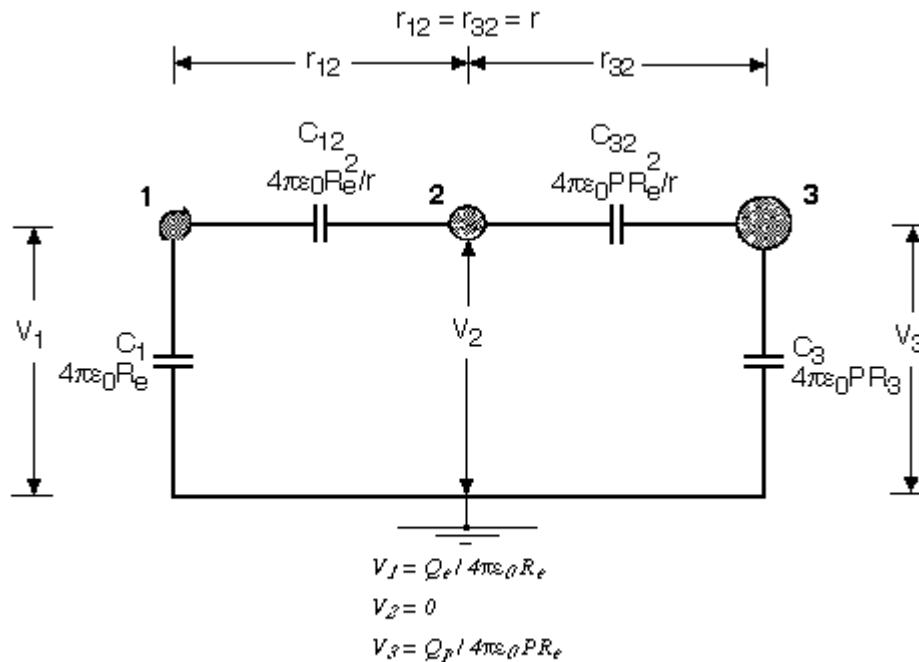
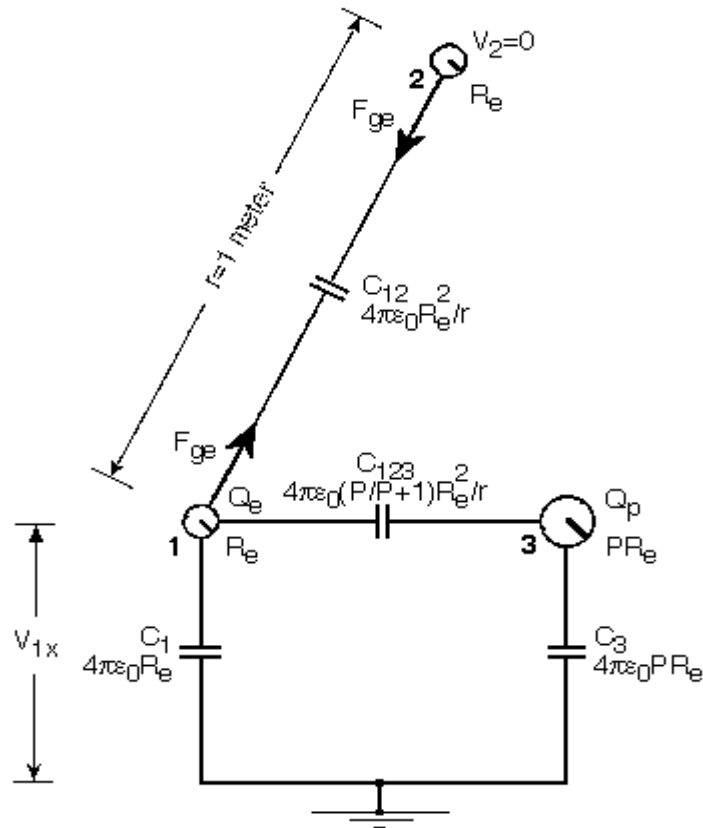

Figure 2. Electrostatic Circuit Diagram of Model

Note by Leigh Tesfatsion (3 June 2010): There is a typographical error in Fig. 2. “R₃” should read “R_e”.

Next, the circuit in Figure 3 is used to derive the induced voltage V_{1x} at position 1 by using Thevenin's Theorem. The voltage at position 1 coming from the proton at position 3 is induced through C_{123} , but it appears at position 1 to arrive via a capacitance C_{12} from a particle at position 2. The charge (or voltage) of the electron at position 1 is not used in this kind of determination; but the electron's capacitance serves as the load across which V_{1x} appears.



$$\begin{aligned}
 F_{ge} &= (1/2) Q_e V_{1x} / r^* & V_{1x} &= (Q_p / C_3) \times (C_{123} / C_1) \\
 &= (1/2) [Q_e] [Q_p / (P+1) 4\pi\epsilon_0 r] [K/r] & &= Q_p / (P+1) 4\pi\epsilon_0 r \\
 &= [K/8 (P+1) \pi\epsilon_0] Q_e Q_p / r^2 \\
 &= -5.54779 \times 10^{-71} \text{ coulomb-volts / meter, or newtons}
 \end{aligned}$$

Figure 3. Schematic Diagram from Model to Determine the Force Between Electrons at Positions 1 and 2

Figure 3 is next used to calculate the force between electron 1 and electron 2. The voltage V_{1x} at electron 1 relative to the zero voltage at electron 2 is encountered at the charge Q_e . All normal space-attenuated V/r fields have been cancelled to near zero between the two electrons, which negates any normal $QV/2r$ capacitance force between the poles. However, Q_e can use a different kind of V/r voltage-gradient "field" available between 1 and 2 to construct another force. There is an available voltage gradient V_{1x}/S_{12} between 1 and 2. The voltage gradient V_{1x}/S_{12} through the capacitor C_{12} is the same as V_{1x}/r^* , which is convertible to KV_{1x}/r . The resultant force F_{ge} between the two electrons is then

$$\begin{aligned}
 F_{ge} &= (1/2) K Q_e V_{1x} / r, \text{ and after substitution for } K \text{ and } V_{1x}, \\
 &= (1/2) [8.83538 \times 10^{-40}] (Q_e) [Q_p / (P+1) 4\pi\epsilon_0 r] / r.
 \end{aligned}$$

For the general gravity force between any two masses,

$$F_g = F_{ge} A = F_{ge} M_1 M_2 / M_e^2 .$$

This derivation of electrostatic gravity forces could just as well have been based upon the force between the position 3 proton and the electron in the far-spaced hydrogen atom, with exactly the same value derived for G. However, if the forces are derived between either the position 1 electron or the position 3 proton to the distant proton, it must be considered that a proton consists of not just one particle, but a number of smaller particles with each particle having its own associated force to other far-spaced particles. If one concludes that the proton has the equivalent of about 1836 times the number of particles that make up the electron, it will appear for the electrostatic model as if about 1836 electrons without any charges are situated at the proton position in the far-spaced hydrogen atom. With this approach all of the interactions result in appropriate gravity forces. This multi-particle assumption for the proton appears to be a correct assumption because it also reconciles an apparent anomaly when using Einstein's $E = Mc^2$ expression applied first to the electrical energy of the electron and then to that of the proton.

So far, an apparently straight forward electrostatic method for the determination of gravity forces and the value of G has been presented. However, there are two things that might introduce discrepancies when one empirically measures G. The first involves the assumption that the mass of a hydrogen atom is equal to the sum of the proton and electron masses. The second involves solutions which are made only with a model immersed in ϵ_0 permittivity background.

The ratio of the hydrogen effective mass M_h to the mass of the proton plus the electron is important in this paper because, if less than 1.0, it would effect slightly smaller values for the electrostatic gravity forces and for G. For example, if the mass-ratio were 0.998, both the forces and G would have to be multiplied by this factor because the electrostatic forces derived are all in terms of the electron and proton effective radii and masses. To determine an actual mass-ratio for hydrogen, a "quantum" method and an "electrostatic" method were both tried to find the value of $M_h / (M_p + M_e)$. In the quantum method, the hydrogen binding energy converted to mass, M_B , was subtracted from the proton-plus-electron mass, so that

$$\text{Mass-Ratio} = (M_p + M_e - M_B) / (M_p + M_e),$$

where from Reference [3] the hydrogen binding energy converted to mass is

$$M_B = M_e Q_e^4 / 8 \epsilon_0^2 h^2 c^2 ,$$

and h is Planck's constant, 6.626176×10^{-34} joule-seconds. This method found that the binding mass was less than 10^{-7} times the proton-plus-electron mass. Therefore, from the

quantum analysis, the hydrogen mass-ratio stays as exactly 1.0 for the force and G values as determined to six places herein.

The electrostatic method to determine the mass-ratio of hydrogen involves the effect of C_{13} (not shown in the model), which is the capacitance between the proton and the electron within the hydrogen atom. C_{13} is effectively added in parallel across C_1 and C_3 . Since the mass of a charged particle is proportional to its energy, Q^2 / C , the new effective mass for the proton is proportional to $Q_p^2 / (C_3 + C_{13})$ rather than to Q_p^2 / C_p , and the new effective mass for the electron is proportional to $Q_e^2 / (C_1 + C_{13})$ rather than to Q_e^2 / C_e . The expression for C_{13} is $4\pi\epsilon_0 R_p R_e / r_{13}$ and depends on what value one picks for the distance r_{13} between the proton and the electron. A search through the literature found values ranging from a minimum of 0.528×10^{-10} meters to a maximum of 1.28×10^{-10} meters. The worst-case radius for the hydrogen atom; that is the value that affects the mass-ratio the most, is the minimum value derived on page 276 of Reference [3]. This lessens the effective mass of the electron by about 9.8% and the effective mass of the proton by about 0.0053 %, arriving at an overall mass-ratio for hydrogen of about 0.99989.

The hydrogen mass-ratio values found by either the quantum or electrostatic means just shown are so nearly equal to 1.0 that any change would be trivial, hence the values in this paper remain as derived for the electrostatic gravity forces and for G.

Next, the effects on the solutions for gravity forces and G are determined when the derivations are not for masses in an ϵ_0 permittivity background. This means that, while the expressions apply to gravity between electrons, protons and hydrogen atoms in free space, they may not universally achieve the same results as those from empirical measurements. For example, when the three epsilon values of ϵ_1 at position 1, ϵ_3 at position 3, and ϵ_{12} in the path between positions 1 and 2 are carried along in the derivation for the general electrostatic expression for the gravity force, the gravity force expression becomes

$$F_g = [KQVA / 2r] \times [\epsilon_{12}^2 / \epsilon_1 \epsilon_3] .$$

What does this dependence upon permittivities mean? Presumably, within the hydrogen atom where the voltage values relative to the background are formed, one might expect the permittivity to be always ϵ_0 , so that $\epsilon_1 = \epsilon_3 = \epsilon_0$. However, for very miniscule fields as used in this paper, there is an entirely different scenario. All objects and materials appear as relatively large open spaces peppered with tiny particles. The epsilon values represent *effective* permittivities, which increase as more tiny particles are packed into a given volume of an object or material; that is, as the density increases. In Reference [1] an apparent permittivity increase was demonstrated by adding tiny particles in the air space between the plates of an air-dielectric capacitor. This suggests that elements and materials may have internal effective epsilon values for very small fields that range from a minimum of ϵ_0 for hydrogen, on up to, say, $k_u \epsilon_0$ for uranium 238, where k_u is the internal effective dielectric constant of uranium 238. At the present state of the art for electrostatic

relations within atoms, it is not possible to predict accurate theoretical values for internal miniscule-field dielectric constants of various elements and materials.

Externally viewed, the mass of an object decreases relative to its total internal particle masses. This decrease is caused by some function of the packing density, which includes the effect on F_g , if any, of $(\epsilon_0^2 / \epsilon_1 \epsilon_3) \leq 1$. Whatever this effect does, as long as it does not change the mass of hydrogen, it is automatically removed in the expressions derived in this paper because the effective radii used are directly proportional to the externally-viewed masses. However, any effect in the path between masses is not removed. Therefore, if we let G_0 denote a base G derived in ϵ_0 space, then a measured G is

$$G = G_0 \epsilon_{12}^2 / \epsilon_0^2 .$$

If an experimenter is attempting to determine G empirically by measuring the force between two masses, he or she should be aware of this effect and account for the nature of the path between the masses, if possible. The path could, for example, run almost entirely through the mass materials being used, if measured between two closely spaced bodies. On the other hand, there could be a relatively large ϵ_0 spacing. The G_e value determined herein, for example, is the right one to use without correction for a path between any two far spaced planets, galaxies, or the like. For those objects weighed on earth, ϵ_{12} is the earth's effective permittivity because almost all of the path between the two masses of interest is through the earth. Unfortunately, at the present time there is no way of calculating the extent of the earth's path effect on the weight of an object. The earth's effective permittivity might be measured, however, by noting the reduction in weight of an object versus the distance it is moved away from the surface of the earth. Any such reduction in excess of the square-of-the-distance fall-off from the center of the earth is then due to a squared function of the earth's internal effective permittivity. The authors of Reference [5] measured such an effect but did not relate it to an effective permittivity.

4. Electrostatic Gravity Background

An electrostatic force F takes the form of a charge Q multiplied by a voltage gradient E . E may alternatively be denoted as a voltage/distance term V/r , resulting in the expression for the force $F = QV/r$. In the MKS unit structure, F is the force in newtons, Q is the charge in coulombs, V is in volts (electrical potential relative to another electrical potential), and r is a distance in meters. The ratio V/r is spoken of as a "field" of a magnitude given in volts per meter. The force between two point charges 1 and 2 in free space, from this same conception, evolves into the (Coulombs Law) expression $F = Q_1 Q_2 / 4\pi\epsilon_0 r^2$, where ϵ_0 is the property of "permittivity" (farads/meter) in the vacuum medium where the field links r-spaced Q charges 1 and 2. If the expression yields a negative force for F (one Q positive and the other negative), there is attraction between points 1 and 2. Conversely, when both Q charges are either positive or negative, the force F is positive and results in repulsion between points 1 and 2.

However, there are other types of voltage gradient "fields" besides the well established and much used volts per meter. For example, if an electrode is placed in the ocean and energized with a voltage source, V/r "fields" emanate from the electrode; but the real "field" magnitude is not determined by the distance r in the denominator but rather by the ohmic resistance causing a drop in the voltage with distance. The V/Ω (volts per ohm) ratio is called an electric current I in amperes and is usually not thought of as a "field". Similarly, if an electrode is placed and energized by a DC (steady-state amplitude) voltage source in open vacuum space, a DC field V/r emanates from the electrode; but if the "field" links two entities, the magnitude of the "field" between them is really determined by the capacitance C between the two entities and the capacitances of the two entities to background space (instead of a simple V/r conception). The real "field" is a voltage drop through the capacitance in space and can be altered from a straight-line V/r field by directing it onto a new path (through a curved rod of greater permittivity than the surrounding space, for example). The voltage-drop "field" is V/S , where S is the inverse of capacitance, called elastance in units of darafs. The capacitance "field" can also be expressed as VC (volt-farads), which has the units of coulombs. Since there was no other available name for such a "field", it was designated a Q_f (coulomb) field in Reference [1].

The question then arises whether there is a force $F = QQ_f$ (or $F = QV/S$) as there is for $F = QE$ (or $F = QV/r$). Astonishingly, the answer is yes. When applying $F = QV/S$ to electrical circuits in space involving the capacitances between hydrogen atoms, the forces obtained are forces agreeing with the Newton $F = -GM_1M_2/r^2$ gravity forces within 0.2%, when the G applied in the Newton expression is the generally accepted value. Furthermore, for a capacitance there is an equivalent mathematical relationship for the work required for a change in energy ΔU between the poles when moving from one pole to the other in linear distance specified either in meters or in darafs; that is,

$$\Delta U_1 = (1/2)(QV/r) \times \Delta r;$$

$$\Delta U_2 = (1/2)(QV/S) \times \Delta S.$$

A book (Reference [1]) was written about this in 1991. A great deal of the writing in the book was expended (and not quite correctly, as it turns out) trying to account for the 0.2% difference. The biggest obstacle shown by the feedback responses, however, concerned an apparent inability to convert from one system of units to another in the gravity force equations. The explanation in the book, as viewed in present-day understanding, was on the right track and obtained correct results but lacked a complete description of the method used, which does convert in all systems of units.

In 1993, the units-conversion difficulty precipitated a second book (Reference [2]) based upon capacitance forces of $CV^2/2r$, an acceptable arrangement of units for forces. However, an arbitrary selection of the effective radius of the electron for capacitance (as if it were a plastic-like material) was required to make the theory agree with Newton's force. This seemed a reasonable enough approach at the time, especially as there was no universal agreement among physicists for the make-up or value of the electron radius. Fortunately,

Trevor Silvey, a brilliant engineer from England, kept searching to find out why the results in Reference [1] were so accurate, even if there were seemingly wrong results when converting to units other than MKS. He took no stock in Reference [2] and worked diligently, using relativity and other means, to bring the first book's concepts into fruition. After much correspondence back and forth with Trevor, two things happened to change the direction back again to the first book's concept, and to realize possibly a terrible waste of three years on the second concept.

First, in the April 29, 1995 issue of Science News (Reference [3]), an article appeared entitled "Gravity's force: Chasing an elusive constant" that showed a range in MKS units of four measured G values from a low of $6.6656(6) \times 10^{-11}$ (Fitzgerald et al.) to a high of 6.71540×10^{-11} (Michaelis et al.), and represented a spread range of about 0.75%. The theoretical G value of 6.68541×10^{-11} from Reference [1] falls in between, only about 0.19% above the accepted value of $6.67259(85) \times 10^{-11}$, which itself falls within the range. Therefore, there is now a realization that a 0.2% difference is well within the tolerances being considered for G and the discrepancy should never have been a worry.

Second, after back and forth exchanges of ideas with Trevor Silvey and with further review of the original equation, it became clear why the units do not seem to agree in the $QV/2S$ versus $QV/2r$ picture of forces, yet actually do so. This unit conversion difficulty has been a big obstacle preventing readers of Reference [1] from accepting the electrostatic approach to gravity. However, it is really a simple matter to convert from one system of units to another, but it somehow escaped resolution all this time into an understandable and acceptable mathematical form. In the search for the solution, the volts/ohm "field" analogy served as a means to realize how to convert volts/ohm to volts/meter in seawater; then, following, how to convert volts/daraf to volts/meter in space.

For an uncomplicated analogy, consider the example of a linear one megohm resistor one meter long with an end-to-end potential difference of one volt. One can quickly observe that the magnitude of the volts/ohm for this resistance is simply 10^{-6} volts/ohm; and the "field" volts/ohm is simply the electric current I, which remains the same 10^{-6} amperes no matter what system of units is applied for the resistance. One can also quickly see that the length of one ohm is 10^{-6} meters. The difficulty for so long has been the use of these kinds of relations without stating them in acceptable mathematical terms. Actually, the mathematical conversion of V/Ω to V/r in the given one megohm physical system is: $V/r = 10^{-6} V/\Omega$ (volts/ohm) multiplied by 10^{-6} (the number of meters)/(the number of ohms) times 10^6 ohms/meter. The V/S volts/daraf "field" is converted to a V/r volts/meter field in the same manner by multiplying the V/S volts/daraf "field" by (the number of meters)/(the number of darafs) times the darafs/meter in the physical system defined. The conversion ratio multiplier term is a pure number that stays the same in all systems of units for the physical system defined.

5. Concluding Remarks

Purely classical physics principles have been used to determine magnitudes of electrostatic forces between sub-atomic particles, atoms, and larger neutrally-charged

bodies. The magnitudes of these forces fall within the range of values determined by empirical measurements of gravitational forces, and are therefore assumed to be gravitational forces. From a model depicting two hydrogen atoms separated in free space, electrostatic schematic circuits and expressions are derived which permit solving, not only for the gravity forces, but also for the value of the illusive gravitational constant G in terms of electrostatic units in any chosen system of units, but specifically in terms of coulomb-volt-meters per kilogram squared in the MKS system of units.

Along with the realization that gravity is almost certainly an electrostatic phenomenon comes a new uncertainty related to the nature of the medium in the path between attracting masses. For ultra-miniscule voltage gradients in the order of magnitude dealt with in this paper, any medium other than vacuum space appears as a large open space with very tiny particles dispersed throughout. If the particles have either some conductivity or permittivity greater than ϵ_0 , and if the medium is between two separated masses, the particles serve to increase the capacitance linkage between those masses. This effect of increased linking capacitance is the same as if a slightly greater permittivity existed in the path between the masses. Knowing the precise *effective* permittivity increase for various elements and materials is not yet state-of-the-art. However, from the expressions used to derive gravity forces in this paper, G is altered by this presently unknown *effective* permittivity ϵ_{12} as shown in the expression:

$$G = G_0 \times \epsilon_{12}^2 / \epsilon_0^2 ,$$

where G_0 represents the G value in ϵ_0 permittivity space, and ϵ_{12} is the effective permittivity in the path between two masses of interest. If sub-atomic particles in media have complete field short-circuiting capabilities, they cause the maximum ϵ_{12} permittivity possible. Assuming this maximum effect for a path through the earth's medium, and using the technique developed in Appendix C of Reference [1] to estimate the effective permittivity of the earth, the effect of increased G at the earth's surface has caused our weights of everything to measure slightly greater than if the path were entirely through a vacuum. Eeckhardt, Jekeli, Lazarewitz, Romaides and Sands, from their tower gravity measurements reported in Reference [5], enforce this hypothesis. They measured, as they moved away from the earth, a very slight extra drop in weights below the normal decrease due to the square-of-the-distance from the center of the earth. This happens in the electrostatic approach also because, while most of the path is still through the earth's medium, a small part of the path is through a lesser permittivity air medium. A careful detailed analysis of their results, or similar new measurements, might yield the true magnitude of the earth's effective ϵ_{12} , at least for the earth's path to the measurement site.

The basic conclusions resulting from this paper will now be summarized:

1. Gravity is an electrostatic phenomenon
2. The gravitational forces and G values determined in this paper are based on forces between particle masses separated by distances in vacuum space that are very great relative to the sizes (effective radii) of the particles themselves.

3. Any experimenter performing precise force measurements between masses does not determine an invariant empirical gravitational constant G , but determines instead a G for the particular physical layout. This is because the effective permittivity of the path between the masses could have a consequential effect. A path, for example, might run mostly through vacuum or air, or mostly through the masses under measurement, or for nearly equal distances through two different kinds of masses. All kinds of physical layouts are conceivable. The gravity that is encountered near the the surface of the earth has its own G value related to a path medium running almost entirely through the earth.

4. It is possible to use classical physics, at least as used herein, to understand interactions between particles within and outside of atoms even though the scale of interaction is less than 10^{-10} meters.

5. Electrostatic gravity suggests fertile new techniques for exploration in several domains. For example, a new tool seems to be available to attack some of the mysteries confronting both cosmologists in large scale environments and quantum physicists in small-scale environments. Other research, more closely related to advancing an understanding of the technique evolved herein, could be important. The following are two suggested examples:

a. Since there are forces based upon voltage gradients in capacitors, might there not be similar types of forces based upon voltage gradients in resistors? The environment and parameters involved appear to be easier to control than for measuring forces in capacitors. For example, it is not difficult to measure forces between electrically energized particles in a wide range of controlled conductivity liquid backgrounds, such as in distilled water or in oil.

b. Only part of the overall force puzzle is addressed in this paper. Another part relates to the derivation for the inertial force, $F = Ma$. Just as the Newton expression for a gravity force between two entities has many of the attributes of the Coulomb expression for a charge force between two entities (mass or charge squared divided by a distance squared), the $F = Ma$ expression contains an acceleration parameter that acts on a mass to create an opposing force, much like inductance acts on an electric current to create an opposing force (back emf voltage). Unless there is an increasing or decreasing current, the inductance has no effect; but when it does, it opposes the increase or decrease of that current. Through open space, the inductance in space (permeability) opposes increases and decreases in velocities of charges which, when moving, are actually electric currents. The above observations suggest that there could be a new electromagnetic expression for $F = Ma$.

References

- [1] Spears, Morton F., *CTG Capacitance Theory of Gravity*. Spears Associates, Inc., Norwood, MA, 1991. ISBN: 0-9629933-0-1.
- [2] Spears, Morton F., *CTG Capacitance Theory of Gravity Book II*. Spears Associates Inc., Norwood, MA, 1993. ISBN: 0-9629933-1-X.

- [3] Resnick, Robert and Halliday, David; *Physics*. John Wiley and Sons, New York, Revised 1978. ISBN: 0-471-34530-X.
- [4] Petersen, Ivars, *Gravity's force: Chasing an elusive constant*. Science News, Volume 147, No. 17 (April 29 1995), Page 263.
- [5] Eckhardt, Jekeli, Lazarewicz, Romaides and Sands; *Tower Gravity Experiment: Evidence for Non-Newtonian Gravity*. Physical Review Letters, Volume 60, No. 25 (June 20, 1988), Pages 2567-2570.